

# Curtain Support Framework Systems

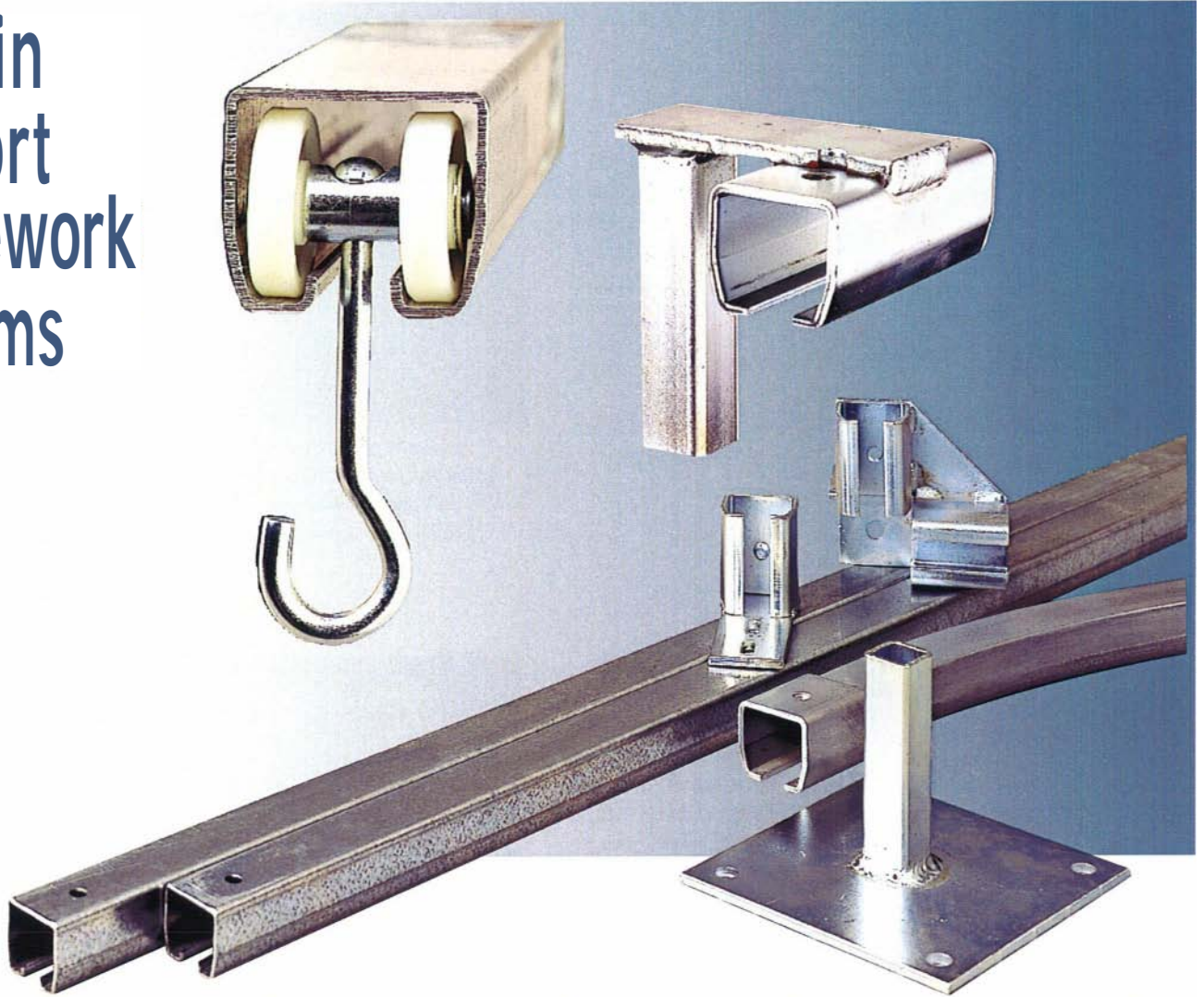

## FEATURES:

- ◆ Designed for installation of Acoustical Curtain Enclosures
- ◆ Floor, suspended, ceiling, beam and wall mounted systems
- ◆ Heavy-Duty structural steel systems available
- ◆ Double track systems allow for slide-open access
- ◆ CAD drawings provided for easy and accurate installation

## Floor Mounted Systems:

Creates a free-standing Acoustical Curtain Enclosure. Designed for easy set-up, reconfiguration and relocation by way of universal, interchangeable parts.

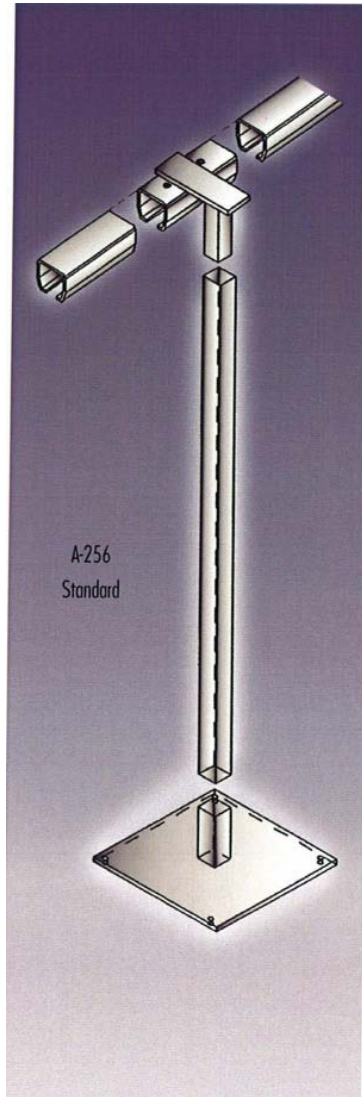

### Roller Tracks:

Universally fitting roller track system works with floor, wall, suspended ceiling mounted or HD curtain enclosures. Made from 16 gauge hot-dipped galvanized steel. Single or double track. Curved track: 2' radius, 90° sgl. or dbl. All track pieces slide into all track connectors.

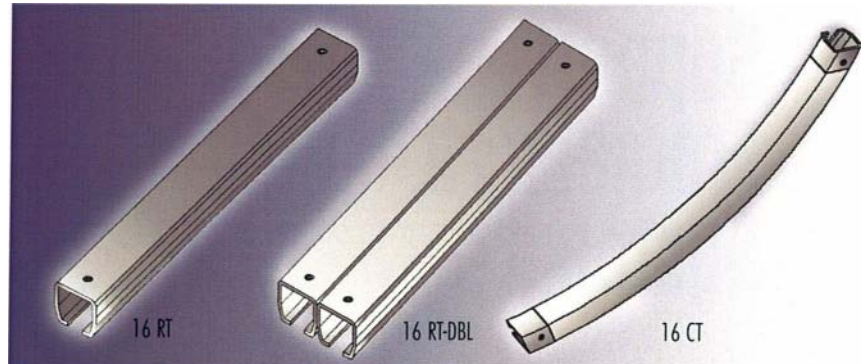

\*16 CT curved piece has flared ends, the same dimensions as a connector piece, and will accept straight track pieces fitted into its ends. Once assembled, it functions as a continuous piece of track. Curved connectors are available with mounting hardware for floor, suspended, wall, ceiling mounted or HD systems.

—Double track is two identical pieces to be used with double connectors, but are not physically joined together.

### Track Connectors:

Universally fitting roller track connectors are made from 12 gauge zinc-plated steel. Single or double track; end, corner, middle.

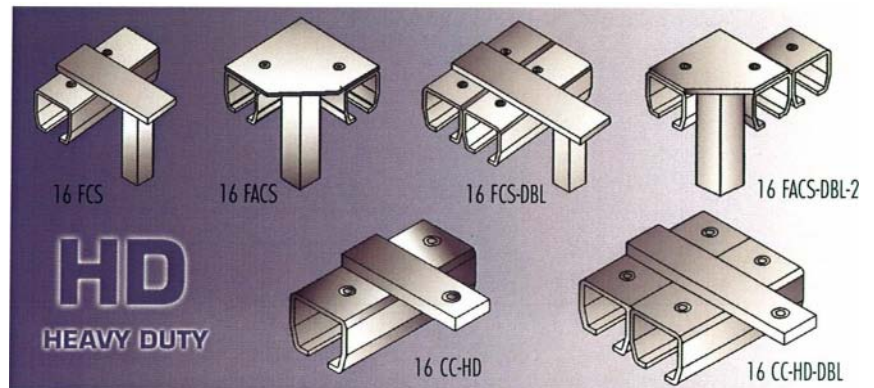

**Standard System:** Made from 12 gauge steel. Columns telescope over bases and connectors up to 12' in height.

**Two floor base options available:** 12" square, 1/4" thick steel plate.  
6" square, 3/16" thick steel plate.

### Universal Track Parts:

Universally fitting rollers available in 1 1/2" nylon, or 1" steel. All hook/roller assemblies use two rollers.

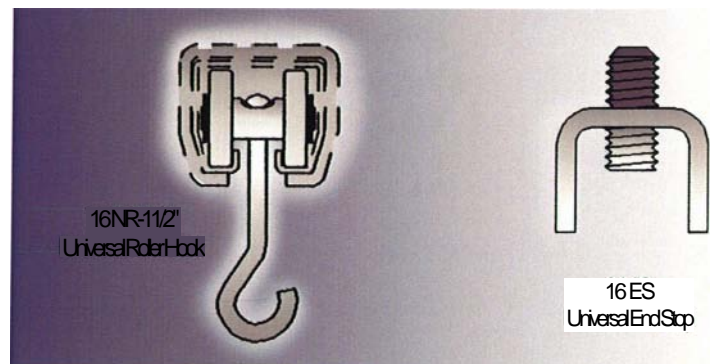

Roller hooks also available with steel rollers

CAD Drawings provided with all enclosures for easy assembly.

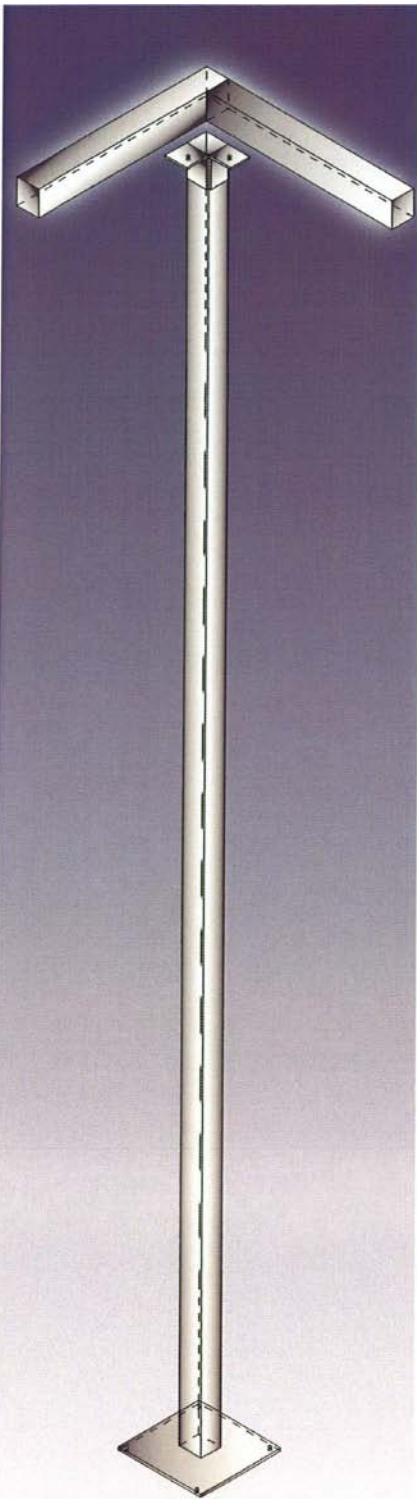

## Suspended Systems

12 gauge, zinc-plated,  
Accepts up to 1/2"  
diam. threaded rod.  
Corner, middle, and curved  
connectors available for single  
or double track systems.  
Utilized to attach to I-beams

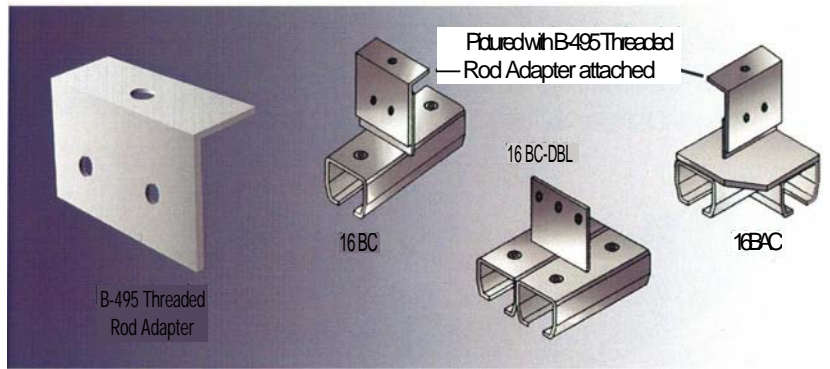

## Ceiling Mount Systems

12 gauge, zinc-plated,  
Corner, middle, and curved  
connectors available for single  
or double track systems.

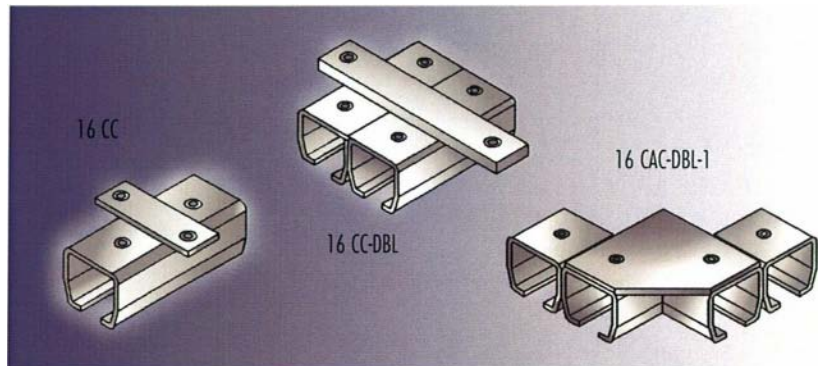

## Wall Mount Systems

12 gauge, zinc-plated,  
Corner, middle, and curved  
connectors available for single  
or double track systems.

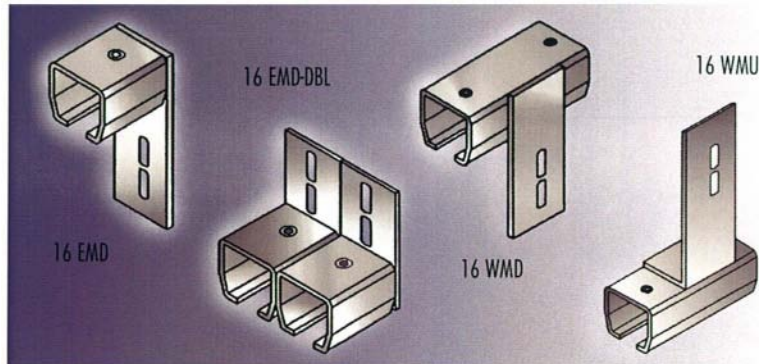

## Stationary Vinyl Strip Door Hardware:

Made from galvanized steel,  
aluminum, or stainless steel.  
8', 10' or custom lengths  
available.  
Includes 1" studs (spaced  
2" on center), clamping  
plates and lock nuts.  
Three styles to choose from.

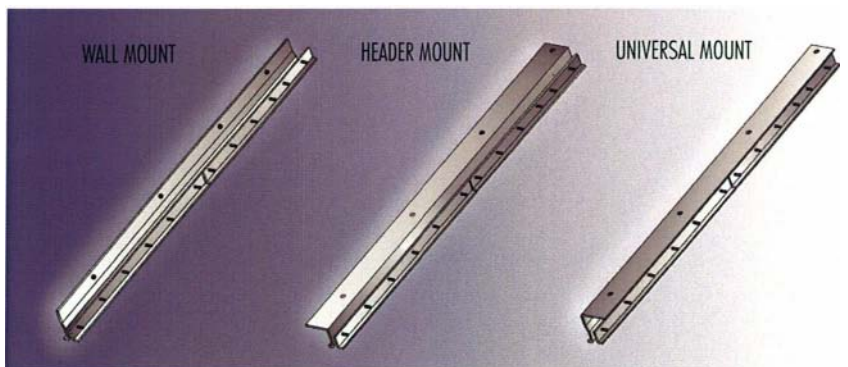

### Heavy Duty System:

Made from 2 1/2" square steel tube,  
3/16" thick. Floor base, column, and  
cross-beam connector angle are one-piece  
all welded construction. HO curtain frames  
are painted for durability.

## Heavy Duty Frame Systems

- ◆ For large or tall enclosures
- ◆ For greater spans between columns
- ◆ Custom sized for any application

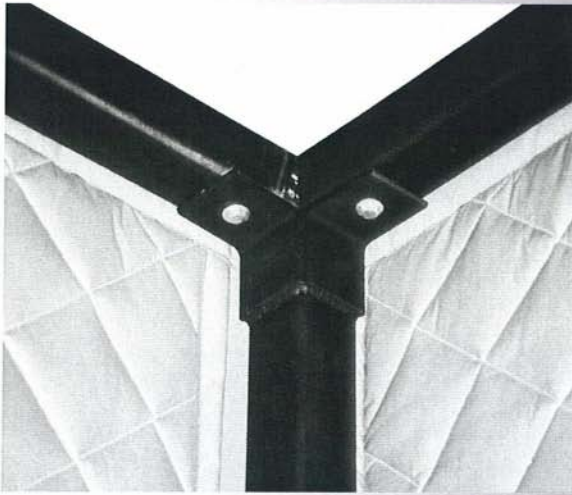

- ◆ Panels may be bolted directly to frame, (photo above) or installed on sliding double track for maximum access (photo below)

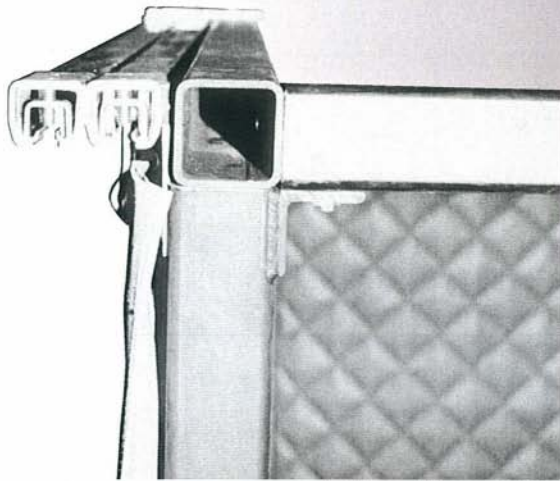

- ◆ Utilizes any style of Industrial Acoustical Curtain Panels
- ◆ 2 1/2" square steel tube framework easily supports roof systems as well as roof top ventilation baffles
- ◆ Shipped knock down with CAD drawing provided for easy installation



- ◆ Rugged Construction
- ◆ Strong structural steel tube
- ◆ Durable painted finish