



"The ART of Noise Control"

For your local ArtUSA Representative

Call: 1-888-454-6973

Internet: www.artusaindustries.us

Sound Attenuator

NO. 782-95

ENGINEERING DATA SHEET

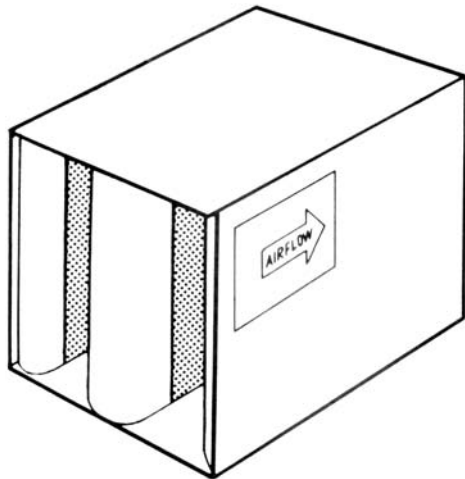

MODEL HP-18

RECTANGULAR

NOMENCLATURE EXAMPLE:

WIDTH	HEIGHT	LENGTH	MODEL
18	24	30	HP-18

Commercial Acoustics sound attenuators are engineered to achieve a maximum insertion loss with a minimum pressure drop. Commercial Acoustics sound attenuators feature airfoil design for efficient aerodynamic performance, as well as superior acoustical materials and totally galvanized steel construction, guaranteeing excellent reliability and performance.

TABLE I

OCTAVE BANDS	(1)	(2)	(3)	(4)	(5)	(6)	(7)	(8)
(Hz)	63	125	250	500	1000	2000	4000	8000
SILENCER FACE VELOCITY, FPM	DYNAMIC INSERTION LOSS IN DECIBELS							
-2000	8	13	18	23	25	20	13	11
-1000	7	12	18	22	22	19	16	14
0	7	11	16	20	20	20	14	14
+1000	5	10	15	18	20	20	14	12
+2000	5	9	15	18	20	20	14	12

TABLE II

OCTAVE BANDS	(1)	(2)	(3)	(4)	(5)	(6)	(7)	(8)
(Hz)	63	125	250	500	1000	2000	4000	8000
SILENCER FACE VELOCITY, FPM	SELF-NOISE SOUND POWER LEVELS dB re 10 ⁻¹² WATTS							
-2000	56	52	50	46	44	49	44	43
-1000	48	45	42	37	37	38	29	30
+1000	46	41	39	43	50	50	39	30
+2000	63	57	55	55	55	59	59	50

TABLE III

SOUND ATTENUATOR FACE AREA, Sq. Ft. *	0.375	0.75	1.5	3	6	12	24	48	96
PWL ADJUSTMENT FACTOR, dB	-9	-6	-3	0	+3	+6	+9	+12	+15

*For immediate face areas, interpolate to nearest whole number.

Static pressure loss, Model 3HP-18 = 0.26 in @ 1000 fpm

Actual fpm = Actual cfm ÷ Actual size in sq. ft.

For other velocities $\left(\frac{\text{Actual fpm}}{1000 \text{ fpm}}\right)^2 * 0.26 \text{ in} = \text{Actual P.D.}$

THIS TABLE CONTAINS BOTH FORWARD (+) AND BACKWARD (-) FLOW ACOUSTIC AND AERODYNAMIC RATINGS BASED ON TEST RESULTS MEASURED IN ACCORDANCE WITH ASTM E477. COPIES OF THESE TEST REPORTS CAN BE FURNISHED UPON REQUEST.